

Features

- Premium CREE XP-L HI V3 LED
- Maximum output up to 1000 lumens
- 'Crystal Coating Technology' combined with 'Precision Digital Optics Technology' provide extreme reflector performance
- Boasts a peak beam intensity of 33,700cd and a throw distance up to 367 meters
- High efficiency circuit board provides up to 520 hours runtime on low level
- Side switch interface provides one-handed operation and easy access to all functions
- Side switch features an indicator light which displays remaining battery power (Chinese Patent: ZL201220057767.4)
- Features advanced temperature regulation (ATR) technology
- Power indicator's secondary function displays battery voltage (accurate to 0.1V)
- Intelligent memory function stores preferred brightness setting
- High-efficiency regulation circuit provides unwavering output
- Toughened ultra-clear mineral glass with anti-reflective coating
- Constructed from aero grade aluminium alloy with HAIII military grade hard-anodized finish
- Waterproof in accordance with IPX-8 (two meters submersible)
- Impact resistant to 1.5 meters
- Stainless steel titanium-plated two-way clip included
- Tail stand capability

Dimensions

Length: 5.51" (140mm)
 Head Diameter: 1"(25.4mm)
 Tail Diameter: 1" (25.4mm)
 Weight: 3.21oz (91g)(without battery)

Accessories

Quality holster, clip, tactical ring, lanyard, spare tail cap cover, spare O-ring

Battery Options

	TYPE	Nominal voltage	Compatible
Primary Lithium battery	CR123	3V	Y (Recommended)
18650 Rechargeable Li-ion battery	18650	3.7V	Y (Recommended)
Rechargeable Li-ion battery	RCR123	3.7V	Y

Brightness & Runtime

FL1 STANDARD	HIGH	MID	LOW	LOWER
	1000 LUMENS	280 LUMENS	55 LUMENS	1 LUMEN
	1h	5h15min	28h	520h
	45min	3h30min	20h	300h
	367m (Beam Distance)			
	33,700cd (Peak Beam Intensity)			
	1.5m (Impact Resistant)			
	IPX-8, 2m (Waterproof AND Submersible)			

NOTICE

The above data has been measured in accordance with the international flashlight testing standards ANSI/NEMA FL1 using one x 3.7V 3400mAh Nitecore 18650 battery and 2 x 3V 1700mAh Nitecore CR123 batteries under laboratory conditions. The data may vary slightly during real-world use due to battery type, individual usage habits and environmental factors.

Operating Instructions

Battery Installation

Insert one 18650 battery or two CR123 batteries with the positive ends pointing toward the light head.

WARNING

Ensure when turning the P12GT on, the beam is directed away from the eyes of people or animals.

Momentary Illumination

Momentary illumination mode is accessed by pressing the tail switch partway down and holding with the flashlight in standby. Release the switch to turn the light off.

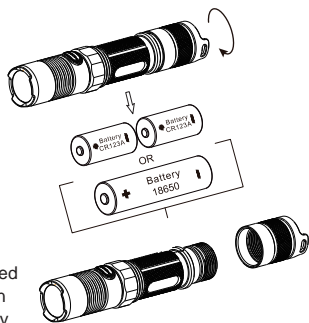

Switching ON/OFF

To switch ON: Press the tailcap switch until a "click" is heard.
 To switch OFF: Press the tailcap switch a second time until a "click" is heard.

General Operations

With the light turned on, press the side switch to cycle through the following brightness levels: ultra-low, low, medium and high. Once a desired setting is displayed, it can be saved by turning the light off at the tail switch.

Special Modes

With the light turned on, press and hold the side switch to activate Strobe mode. Press and hold once again to access Location Beacon mode and repeat once more for SOS mode. To exit any one of these modes simply press the side switch to return to your previously used brightness level.

Note: Strobe mode is the default special mode and is the only special mode that has a memory function. If the light is turned off in strobe mode, strobe will resume when the light is turned on. SOS and Location Beacon modes have no memory function.

ATR Technology

Advanced temperature regulation (ATR) technology allows P12GT to dynamically adjust output performance based on its internal temperature. This prevents damage from overheating and prolongs its working life.

Power Tips

1. With the light switched on, the power indicator will blink once every two seconds when power levels are below 50%.
2. With the light switched on, the power indicator will blink rapidly when power levels are close to depletion.
3. With the light turned off, press and hold the side switch while simultaneously pressing the tail switch to display the battery voltage (accurate to ±0.1V) with serial of blinks. For example, when the battery voltage is at 4.2V, the power indicator will blink 4 times in quick succession, followed by a one second pause and two more blinks.

Changing Batteries

When the power indicator blinks rapidly, the batteries need to be replaced. Alternatively if the light becomes dim or unresponsive to adjustment, this also indicates batteries need to be replaced.

Maintenance

Every 6 months, threads should be wiped with a clean cloth followed by a thin coating of silicon-based lubricant.

Warranty Service

All NITECORE® products are warranted for quality. Any defective / malfunctioning NITECORE® product can be repaired free of charge for a period of 60 months (5 years) from the date of purchase. Beyond 60 months (5 years), a limited warranty applies, covering the cost of labor and maintenance, but not the cost of accessories or replacement parts.

The warranty is nullified in all of the following situations:

1. The product(s) is/are broken down, reconstructed and/or modified by unauthorized parties.
2. The product(s) is/are damaged through improper use.
3. The product(s) is/are damaged by leakage of batteries.

For the latest information on NITECORE® products and services, please contact a local NITECORE® distributor or send an email to service@nitecore.com

※All images, text and statements specified herein this user manual are for reference purpose only. Should any discrepancy occurs between this manual and information specified on www.nitecore.com, information on our official website shall prevail. Sysmax Industry Co., Ltd. reserves the rights to interpret and amend the content of this document at any time without prior notice.

SYSMAX ind.
 SYSMAX Industry Co., Ltd.
 TEL: +86-20-83862000
 FAX: +86-20-83882723
 E-mail: info@nitecore.com
 Web: www.nitecore.com
 Address: Rm1401-03, Glorious Tower, 850 East Dongfeng Road, Guangzhou, China 510600

Please find us on facebook:
 NITECORE Flashlights

